

THIS DRAWING IS UNPUBLISHED. RELEASED FOR PUBLICATION
 © COPYRIGHT BY TYCO ELECTRONICS CORPORATION. ALL RIGHTS RESERVED.

LOC	DIST	REVISIONS					
AJ	00	P	LTR	DESCRIPTION	DATE	DWN	APVD
		T2		REV PER ECO 06-029805	2/6/2007	DW	JL

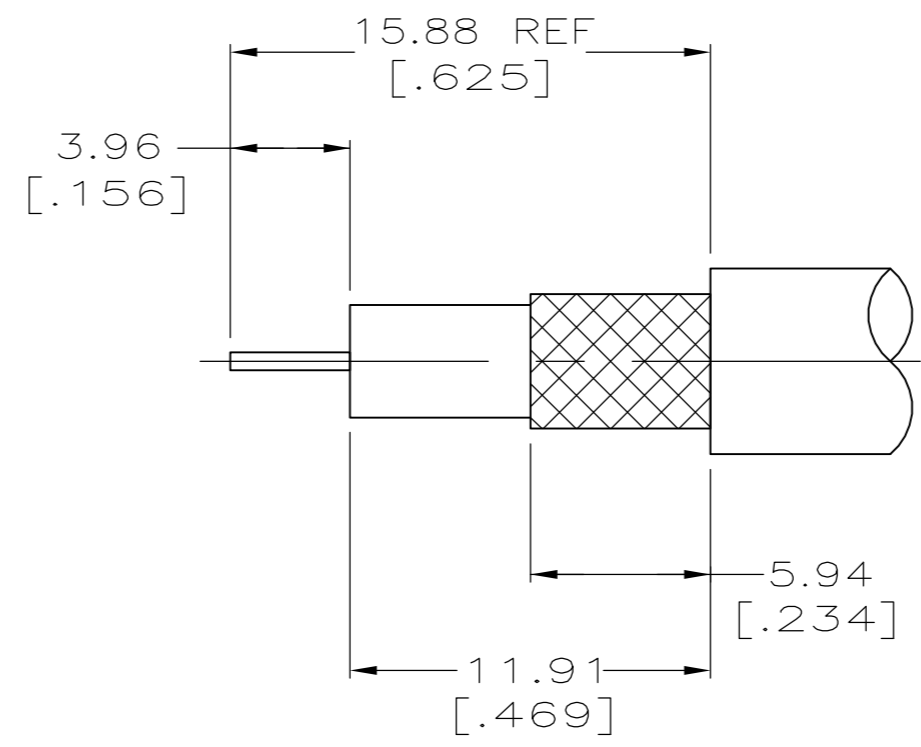
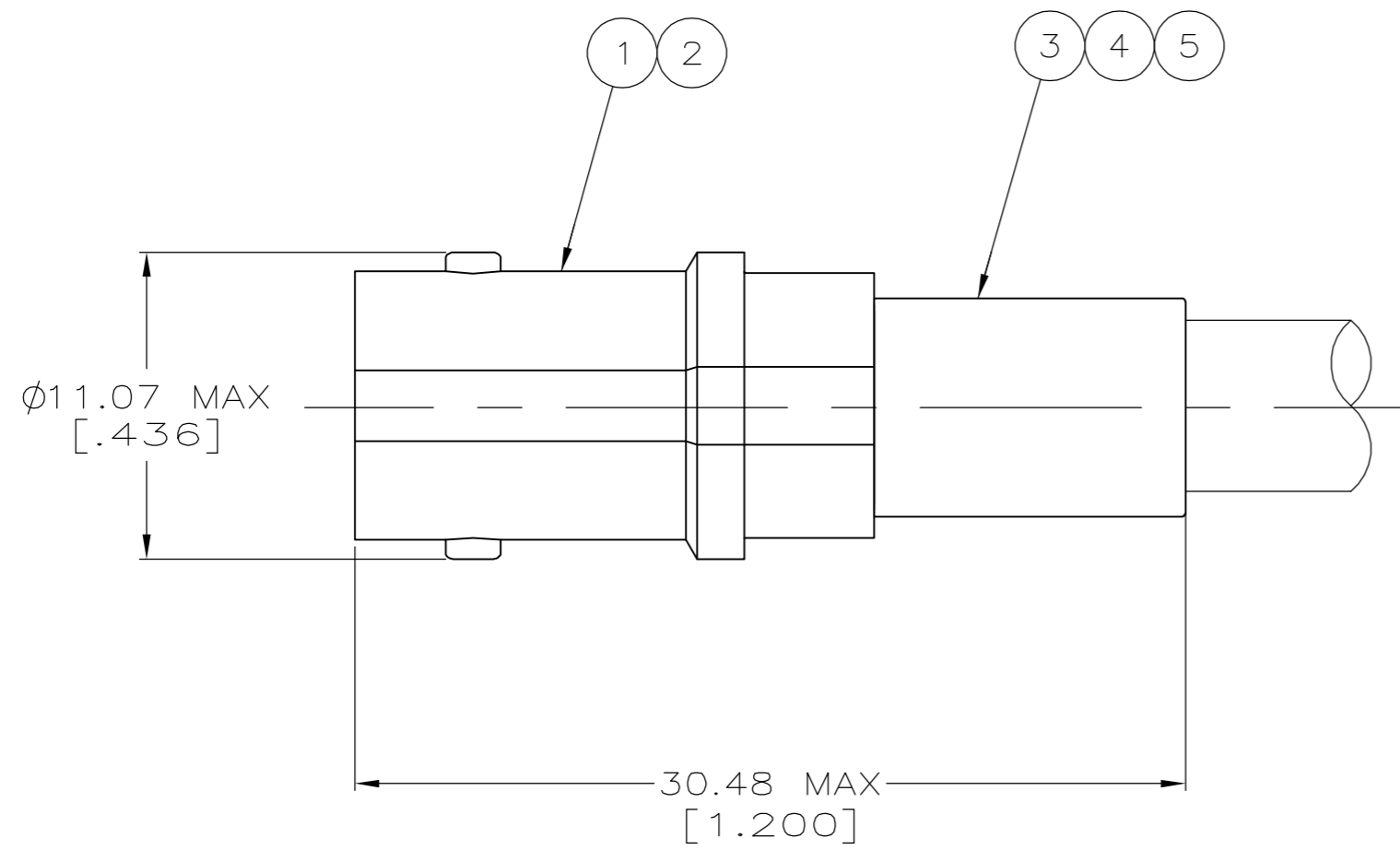

RECOMMENDED STRIP LENGTH

- ⚠ USE CRIMP TOOL: 220190-1 OR PRO-CRIMPER
- 2. USE INSTRUCTION SHEET 408-9090
- 3. DIELECTRIC MUST WITHSHAND A 5 LB PUSH OUT FORCE
- ⚠ 4. SPECIAL PACKAGING
- ⚠ 5. SUPERSEDED BY 221199-2
- ⚠ 6. CUSTOM CABLE:
CENTER CONDUCTOR = ϕ .016
DIELECTRIC = ϕ .070
JACKET = ϕ .110
- ⚠ CUSTOM CABLE:
CENTER CONDUCTOR = ϕ .016
DIELECTRIC = ϕ .075
JACKET = ϕ .120

OBSELETE	RG-59/U,59A/U & 59B/U	58085-1	-	-	9-50428-0	221200-3	221202-2	9-221199-1
OBSELETE	BELDEN 9248, MADISON 18AWG	58086-1	-	-	9-50427-0	3-221200-2	221202-1	9-221199-0
OBSELETE	C&M CABLE 25785	58304-4	-	-	3-328666-6	221200-6	221202-4	221199-9
⚠ OBSELETE	CUSTOM CABLE	58304-5	1-222001-6	414932-3	3-328666-9	221200-9	221202-3	221199-8
⚠ OBSELETE	CUSTOM CABLE	58304-1	222001-8	227194-2	9-328666-0	221200-9	221202-3	221199-7
OBSELETE	AT&T 735A	58174-1	-	-	9-328666-2	221200-9	221202-3	221199-6
	RG-179	58304-1	222001-8	227194-2	9-328666-0	2-221200-0	221202-3	221199-5
⚠ 4 OBSELETE	RG-59/U,59A/U & 59B/U	58085-1	-	-	9-50428-0	221200-3	221202-2	221199-4
SUPERSEDED BY 413760-3	BELDEN 8218	58174-1	-	-	9-329461-0	221200-9	221202-3	221199-3
OBSELETE	RG-59/U,59A/U & 59B/U	58085-1	-	-	9-50428-0	221200-3	221202-2	221199-2
	BELDEN 9248, MADISON 18AWG	58086-1	-	-	9-50427-0	3-221200-2	221202-1	221199-1
	FOR USE WITH CABLE	DIE SET	⚠ 5 TUBING, METAL QTY=1	⚠ 4 TUBING, PLASTIC QTY=1	⚠ 3 FERRULE QTY=1	⚠ 2 CONTACT QTY=1	⚠ 1 JACK ASSEMBLY QTY=1	PART NUMBER

THIS DRAWING IS A CONTROLLED DOCUMENT.

DWN	B. SCOTT	1-15-91
CHK	J. LIPPERT	1-25-91
APVD	M. PHILLIPS	1-25-91

NAME: JACK, 75 OHM, BNC

PRODUCT SPEC: 108-12095

APPLICATION SPEC: -

WEIGHT: -

CUSTOMER DRAWING

SCALE: 4:1 SHEET: 1 OF 1 REV: T2